

**INTRODUCING SOLTECH HYPER:** an economical, easily installed, off-grid solar light that reduces the total cost of ownership and delivers big performance. This fully integrated LED solar streetlight is designed for both residential and commercial areas, with 5,000 and 9,000 lumen outputs. HYPER 25W and 45W provide superior quality light over a greater area. It features an integrated solar array, battery, and LED fixture with simple mounting for fast and easy installation. HYPER solar fixture eliminates trenching, cabling, and electricity costs.

- All-in-one design
- Easy installation and operation
- Remote control included with one-button mode setting
- 3 different mounting options designed for round pole, square pole, and wall pack applications.
- >200lm/W—high efficiency in the industry
- Built-in MPPT controller with microwave motion sensor
- Adjustable angle for the solar panel allows maximum solar collection
- Die cast A380 aluminum fixture housing is rust free

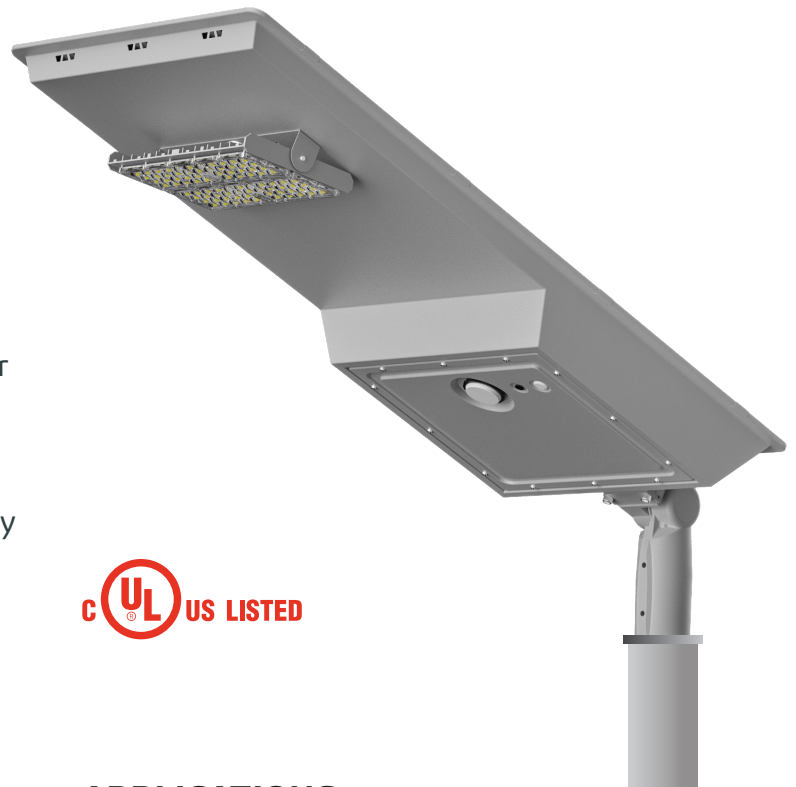

## APPLICATIONS

Pathways, parking lots, landscaping, parks, schools, trails, or any remote locations that have no access to conventional power.



**LIGHT FIXTURES**

LED Nominal Power	25W   45W
Lumen	5000LM   9000LM
Color Temperature	3,000K   4,000K   5,000K   5,700K
Optic Type	Type III
Efficiency@5,000K	200LM/W
Material	Die-Cast Aluminum

**BATTERY**

Operating Temperature	0°C/-4°F to 122°F
Charging Temperature	0°C/-4°F to 122°F
Capacity	27AH 345.6WH   50AH 640WH
Operating Voltage	12.8V

**SOLAR PANEL**

Rating Power	60W   94W
Size	33.0" X 16"   43.0" X 19.0"
EPA	4.6   7.1

**MAXIMUM AUTONOMY**

Motion Sensor Mode	40%–100% 35hrs
	20%–80% 65hrs
Time Control Mode	Night Owl 24hrs
	Early Bird 21hrs
Constant Mode	100% 13hrs
	70% 18hrs
	40% 32hrs

**IES/ BEAM**

**HYPER 25W TYPE III [ MOUNTING HETGHT 20FT ]**

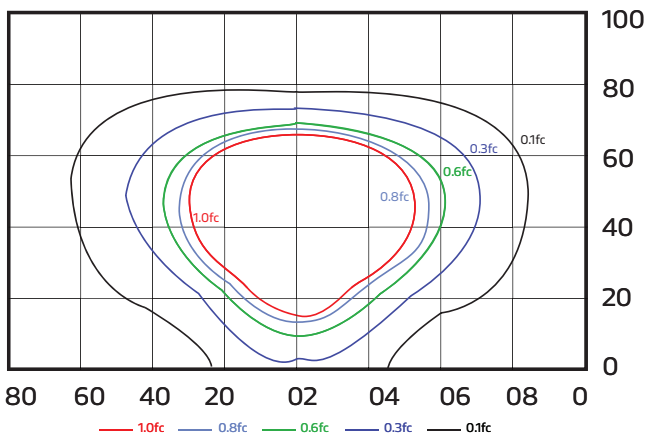

[ UNIT: FT ]

**HYPER 45W TYPE III [ MOUNTING HETGHT 20FT ]**

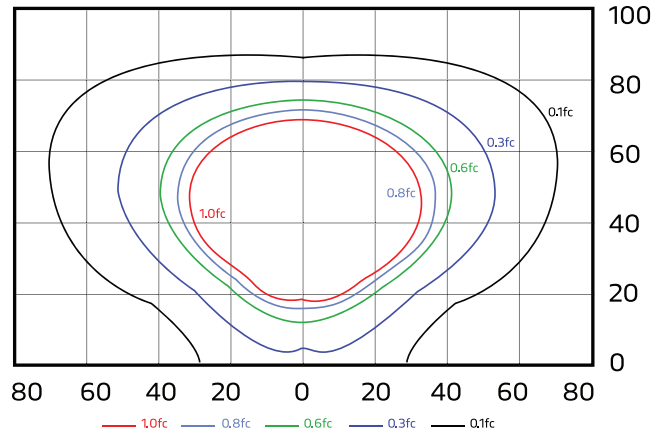

[ UNIT: FT ]

**HYPER 25W**

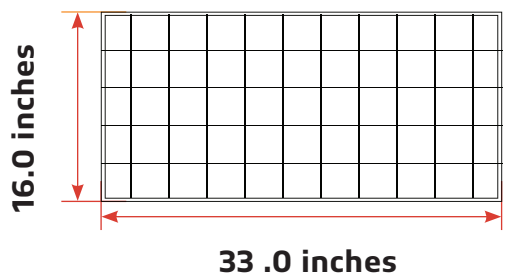
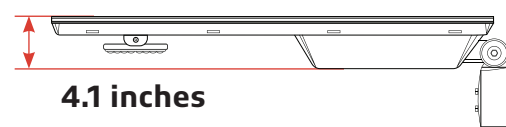
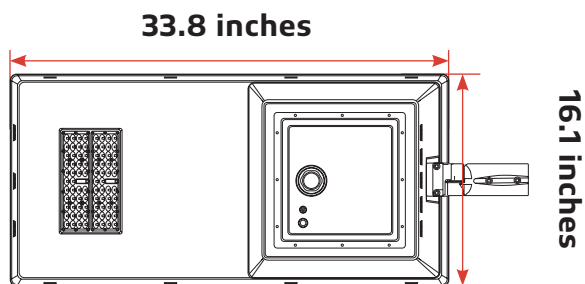

**HYPER 45W**

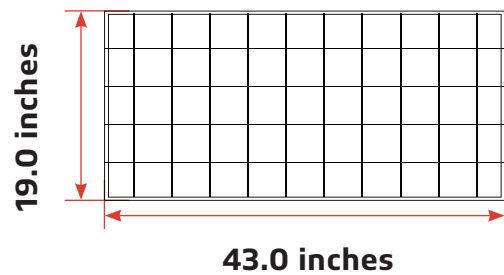
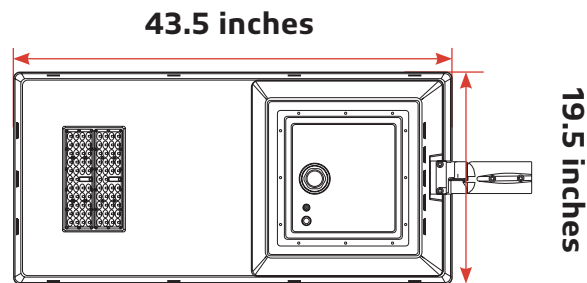

**INSTALLATION ACCESSORIES**

**A. TRUNNION—Wall Mount**

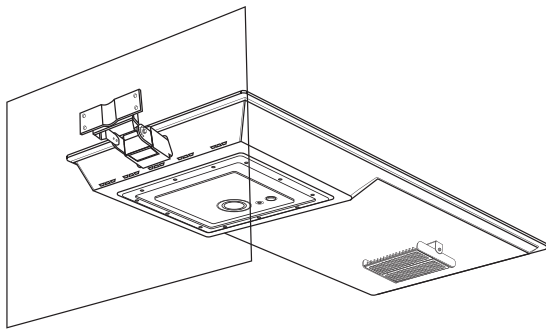

A-a. STLHYB-WM

**B. SLIP FITTER**

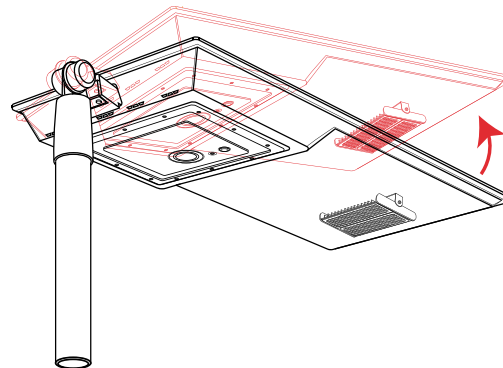

B-b. STLHYB-SF

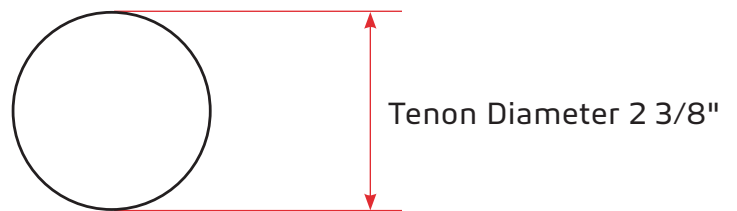

**C. TRUNNION—Round**

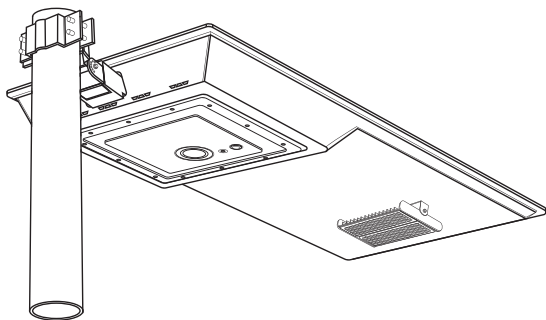

**Round Pole Diameter**

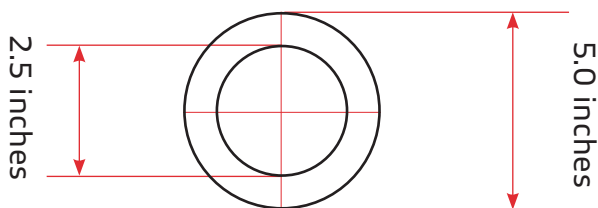

C-c. STLHYB-TRR

**D. TRUNNION—Square**

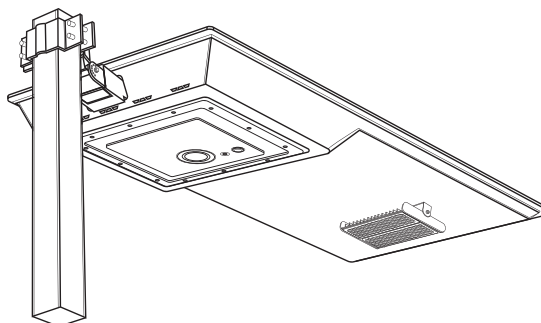

**Square Pole Dimension**

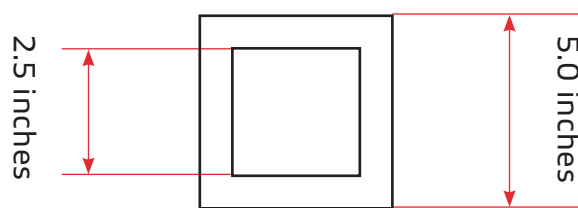

D-d. STLHYB-TRS

**DETECTION ZONE**

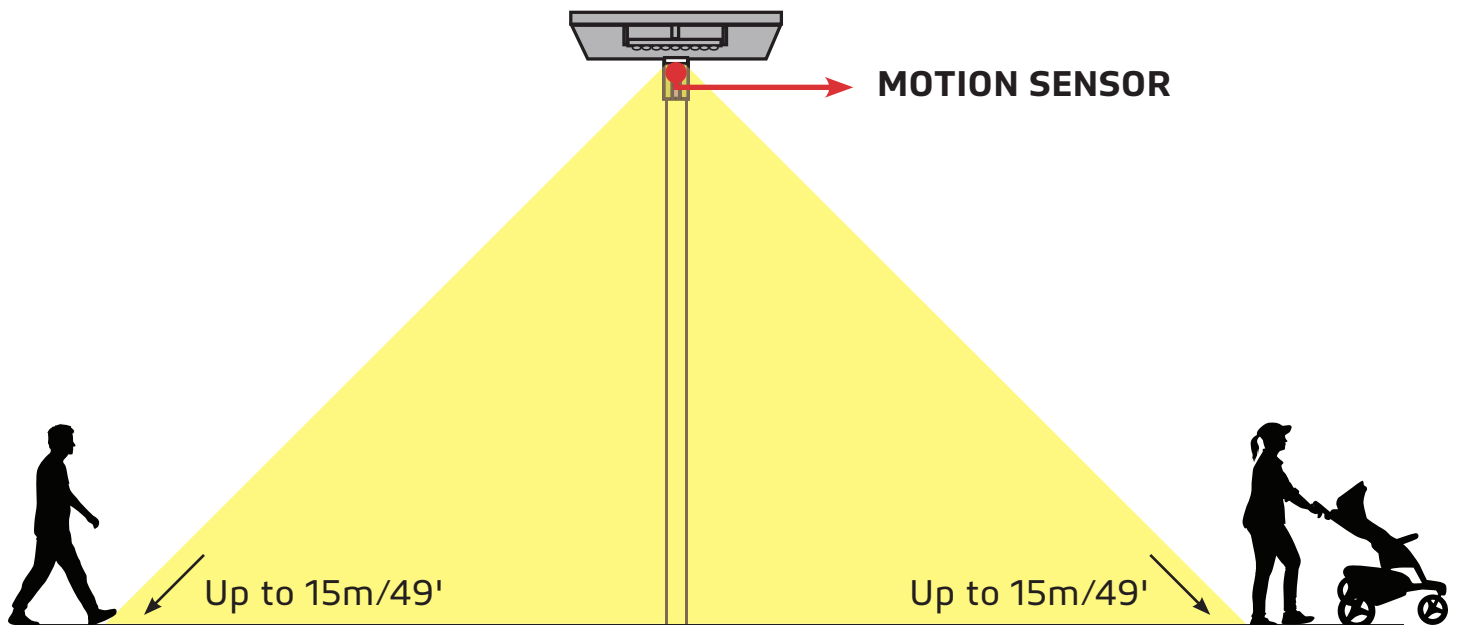

**BEST FACING DIRECTION OF SOLAR PANEL**

The area will dictate the installation of the fixtures and will sometimes prevent the lights from facing south. But that's okay! Panels facing West & East won't get as much light as Southern facing panels, but will still collect a good amount of sunlight. A North facing panel also works, but it will take longer to charge than any other direction. This would mean that the solar charge will be less optimal if installations are facing North.

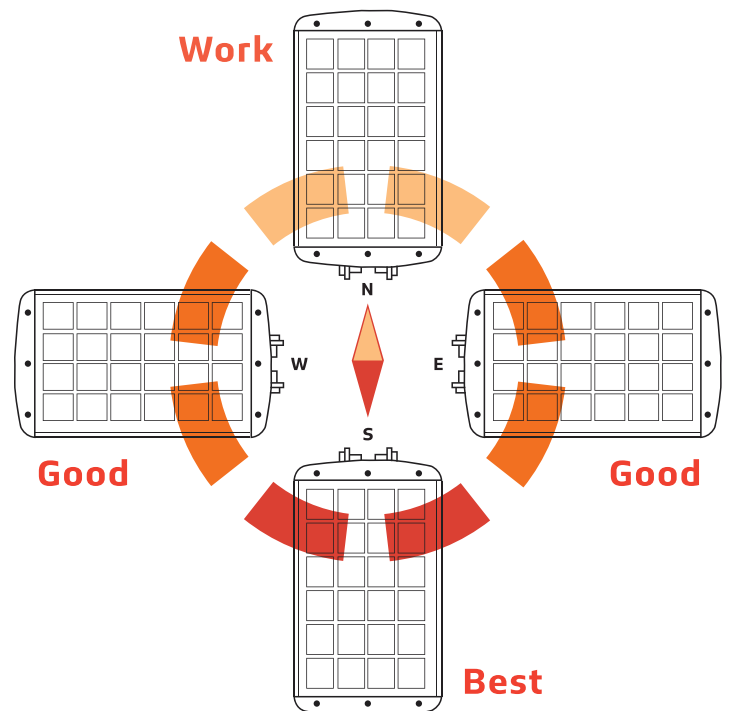

**ORDERING INFORMATION**

SERIES	WATTAGE	OPTIC TYPE	COLOR TEMPERATURE	MOUNTING OPTIONS	FINISH
<b>STLHYB=</b> HYPER	<b>25=25W</b> 5,000LUMENS	<b>T3=TYPE III</b>	<b>3=3000K</b>	<b>WM=WALL MOUNT</b> <b>TR=TRUNNION</b> <b>SF=SLIP FITTER</b>	<b>GY=GRAY</b> (RAL 7038) <b>BR=BRONZE</b> (RAL 8019) <b>BK=BLACK</b> (RAL 9004)
	<b>45=45W</b> 9,000LUMENS		<b>4=4000K</b>		
			<b>5=5000K</b>		
			<b>6=5700K</b>		

-  -  -  -  -

**WARRANTY**

HYPER products are covered by a 5 year limited warranty. SOLTECH urban light warrants to the original purchaser that this product is free from defects in materials and workmanship for the period of 5 years from date of purchase. To obtain warranty service please contact your local distributor or sales rep for further instruction.

**PANEL ANGLE GUIDE**

The solar charge in a battery pack won't last forever. The off-grid system relies on stored solar energy for autonomy. Angling your solar panels properly can boost the power intake of your solar lighting system. You want to angle your solar panels at a tilt based on the area's latitude.

**Key**



Strong sunlight

Nromal sunlight

Less sunlight

**World Wide Panel Angles**

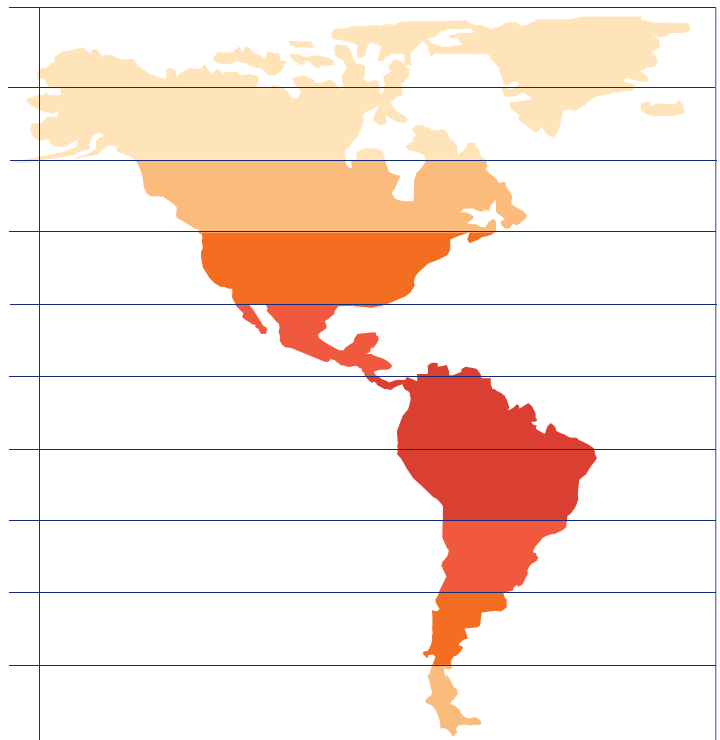
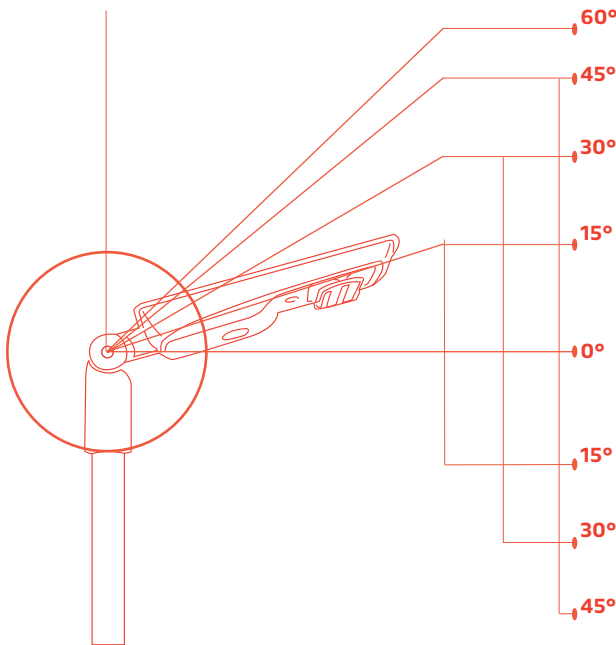

**REMOTE CONTROLS**

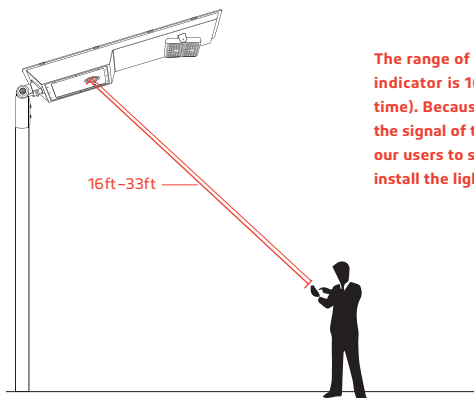
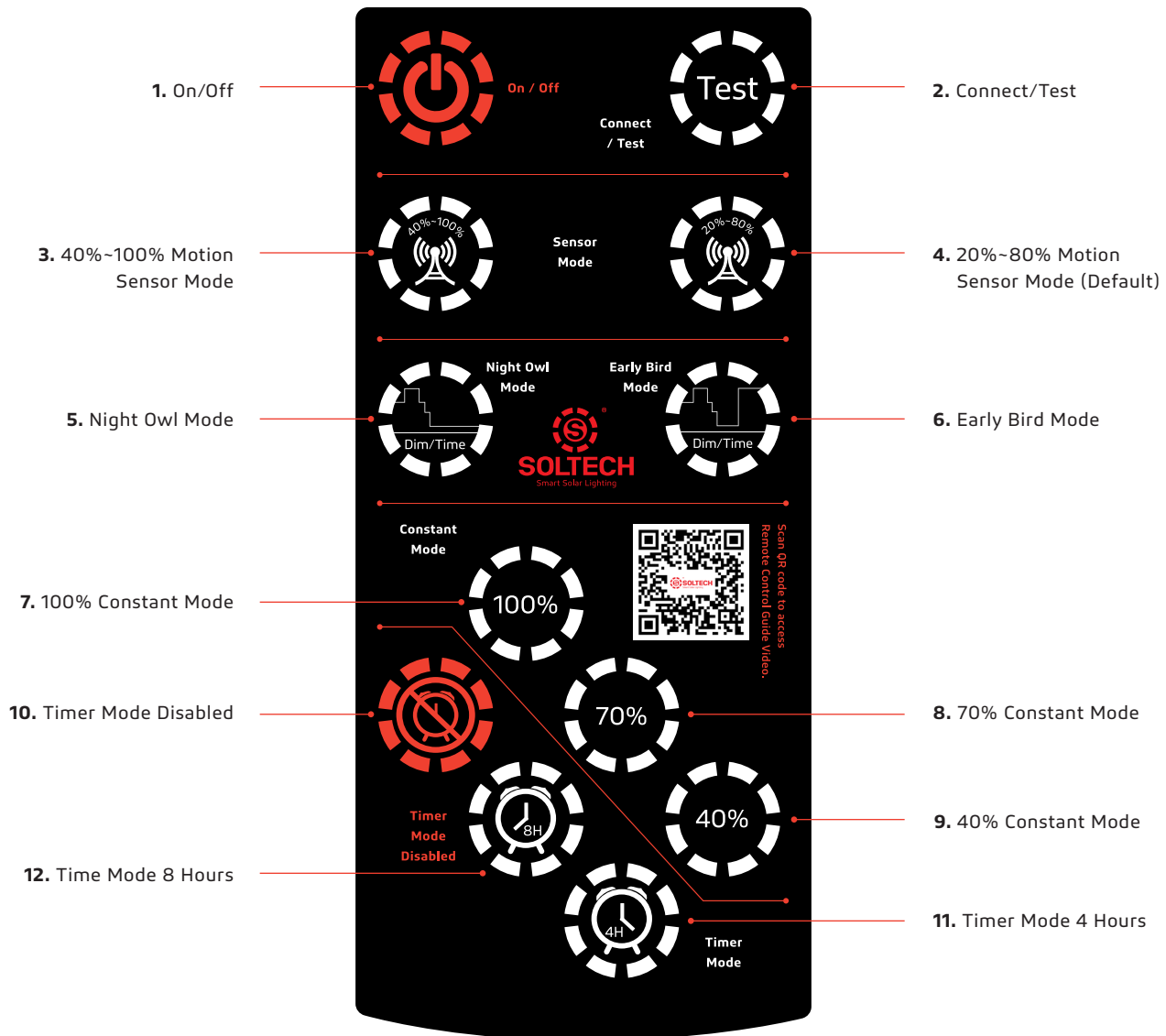

The range of the remote control to the indicator is 16ft (Day time) to 33ft (Night time). Because the sunlight will impact the signal of the remote control, we suggest our users to setup the mode before they install the light.

**1. On/Off**

When off is selected, the light will stop working. The solar panel will not charge the battery and the battery will not supply electricity to the light.

**2. Connect/Test**

Remote control device can be connected with any lighting fixture, one at a time. To connect, press the button once. It also functions as a test button. To test, press the "Test" button once, the red light will indicate the fixture is charging, green light indicates that the fixture is operating. Testing lasts for 10 seconds, and then it goes back to the mode previously in use.



### REMOTE CONTROLS

#### 3. 40%-100% Motion Sensor Mode

Constant 40% brightness (turns on at dusk, turns off at dawn); 100% brightness turns on for 2 minutes when motion is detected.

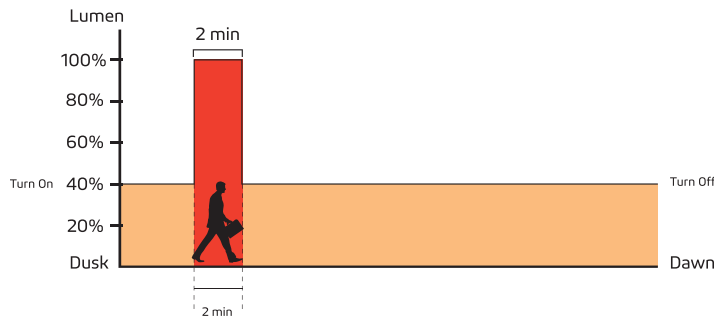

#### 4. 20%-80% Motion Sensor Mode (Default)

Constant 20% brightness (turns on at dusk, turns off at dawn); 80% brightness turns on for 2 minutes when motion is detected.

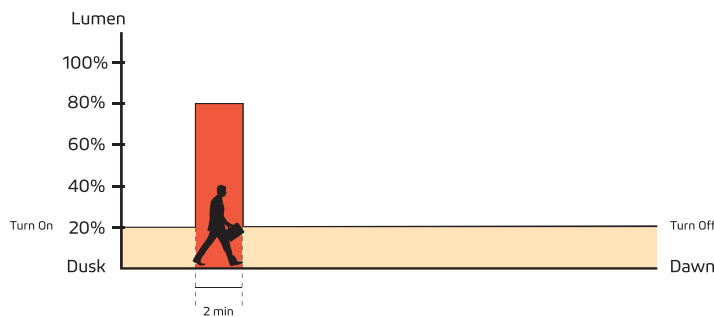

#### (IAP) Intelligent Adaptive Program Battery Control Technology

In order to extend the off-grid autonomy of the HYPER under shady trees, heavy rain, and thick clouds, our controllers now integrate an adaptive smart control feature to actively track battery capacity and adjust light output accordingly. Before integrating this feature, selecting a light output percentage on the remote would yield an accurate percentage of max LED brightness. Now with (IAP), the controller actively monitors the battery and regulates the electrical current to the LEDs. The controller makes light output of the selected percentage on the remote relative to battery capacity rather than max LED output. This smart-control feature can increase our off-grid performance by up to 40%.

#### 5. Night Owl Mode

Changes as natural light decreases/increases (turns on at dusk); 70% brightness for 0.5 hour, 100% brightness for 3.5 hours, 70% brightness for 1 hour, 50% brightness for 1 hour, 20% brightness for 5 hours (turns off at Dawn).

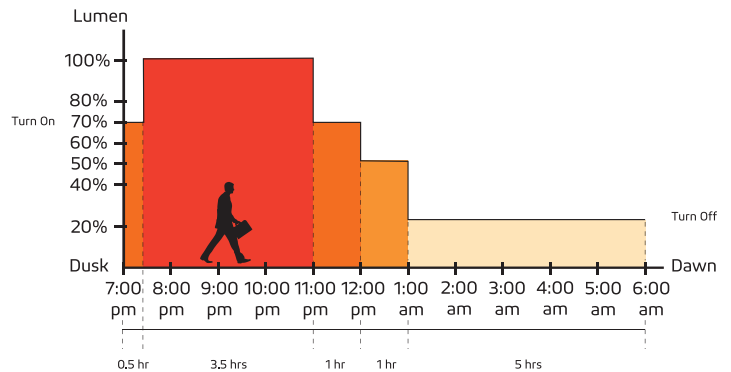

#### 6. Early Bird Mode

Changes as natural light decreases/increases with increased brightness near dawn for early risers (turns on at dusk); 70% brightness for 0.5 hour, 100% brightness for 3.5 hours, 70% brightness for 1 hour, 50% brightness for 1 hour, 20% brightness for 4 hours, 100% brightness for 1 hour (turns off at Dawn).

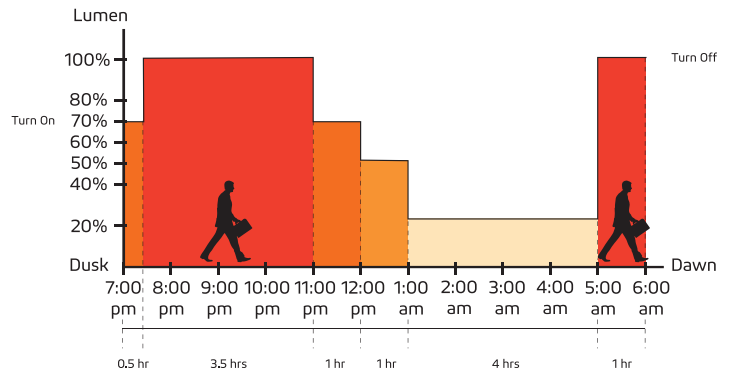

#### Important

Dusk and dawn time may be different in other locations and seasons. The sensors of our products will follow the light patterns of where it is installed. The time period shown in the chart above is just an example to help you understand the different lighting modes only.

### REMOTE CONTROLS

#### 7. 100% Constant Mode

100% brightness from dusk to dawn.

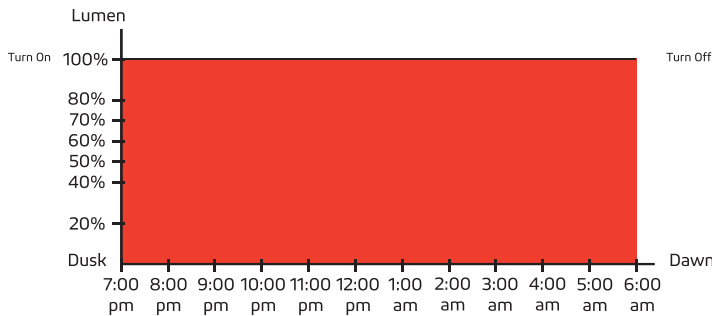

#### 8. 70% Constant Mode

70% brightness from dusk to dawn.

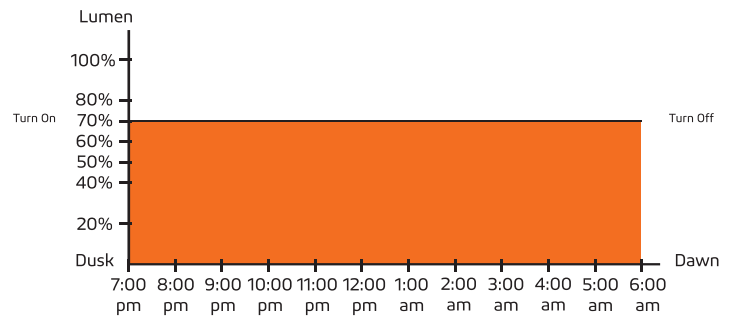

#### 9. 40% Constant Mode

40% brightness from dusk to dawn.

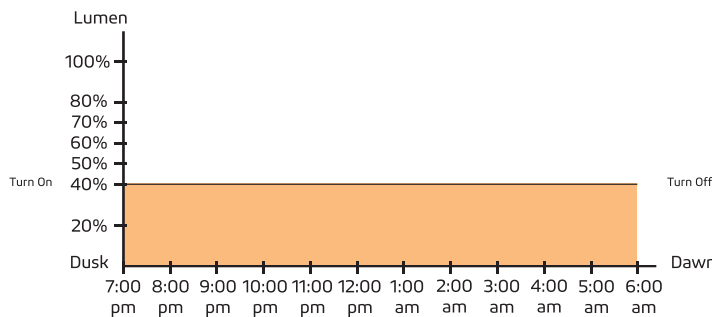

#### 10. Timer Mode Disabled

Press this button to turn off Timer Mode; settings revert back to before Timer Mode was last activated.

#### 12. Time Mode 8 Hours

This is an additional mode which can work with any other modes. For example: press this button at any time after you turn on 70% Constant Mode. If the light turns on at 7pm at dusk, it will turn off at 3am. It will repeat the same schedule hereafter until it is canceled by pressing Timer Mode Disabled.

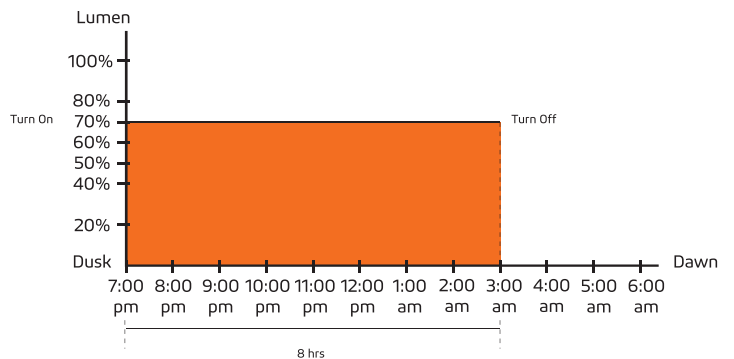

#### 11. Timer Mode 4 Hours

This is an additional mode which can work with any other modes. For example: press this button at any time after you turn on 70% Constant Mode. If the light turns on at 7pm at dusk, it will turn off at 11pm. It will repeat the same schedule hereafter until it is canceled by pressing Timer Mode Disabled.

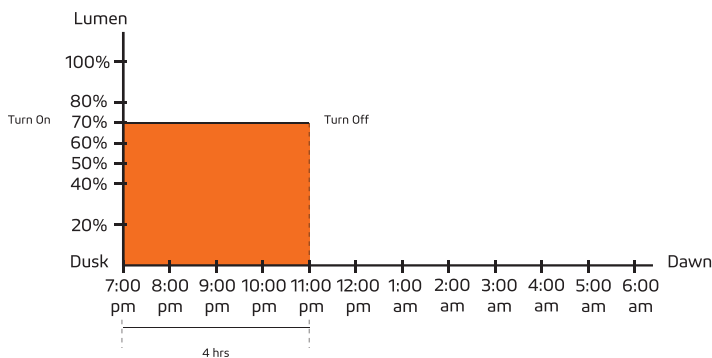

#### Important

Dusk and dawn time can vary for different locations and seasons. The sensors in our products will monitor the light levels where it is installed. The time period shown in the chart above is just an example to help you understand the different lighting modes.

SOLTECH LLC reserves the right to update all product data sheets at any time. Consult SOLTECH marketing specialists for publication updates at [hello@soltechlighting.com](mailto:hello@soltechlighting.com)

Copyright©2018-2024 SOLTECH LLC, All Rights Reserved.